



**IRTA DUPLO & MARKETING**  
**THE NEW PRODUCTIVITY-TIME DIMENSION**

# It's the same!

**Double production  
 or produce in half the time**

In the case of the IRTA DUPLO packaging unit we can easily confirm the above statement because when it makes small bags, it makes them two at a time! It goes without saying that this machine will take your business into a new dimension.

In other words, you can have the peace of mind of being able to produce your orders in half the time or keep up normal production times and cater for twice as many orders. Whatever method you choose you can always rely on the quality-reliability-price factor which define all our machines.

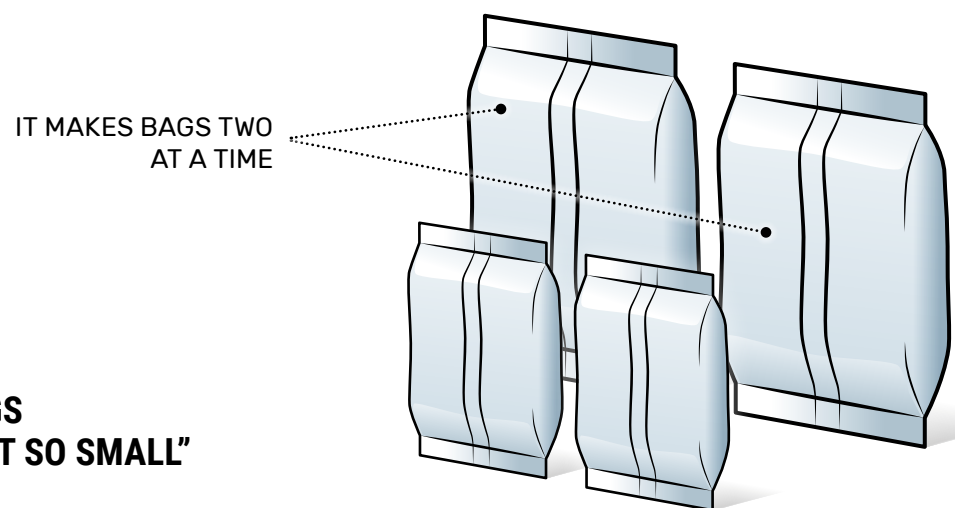

**BAGS  
 "NOT SO SMALL"**

The ability of this robust, compact machine to adapt to any kind of small product and consequently to adjustments in size, will allow you to flood the retail market with your products in record time as well as reaching other niche markets.

**MAKE BAGS  
 FROM  
 50 x 40 mm  
 TO  
 120 x 200 mm**



## LEADERS IN THE MANUFACTURE OF VERTICAL PACKAGING MACHINERY

**WE DESIGN, DEVELOP AND MANUFACTURE  
 MACHINERY, ACCESSORIES AND COMPLEMENTS**

**ADAPTABLE TO ANY KIND OF PRODUCT**

**VAST RANGE OF OPTIONAL EQUIPMENT AVAILABLE**

**MAXIMUM FINISH QUALITY GUARANTEED**

**COMPONENTS FROM LEADING WORLDWIDE MAKES**

**OWN R&D&I DEPARTMENT**

**MADE-TO-MEASURE SOLUTIONS**

**100% OWN DEVELOPMENTS**

**INSTALLATION OF COMPLETE PACKING LINES**

**TURN-KEY PROJECTS**



# IRTA DUPLO

MULTIFORMAT VERTICAL PACKAGING UNIT

**DOUBLES  
 PRODUCTION  
 IN THE SAME AMOUNT  
 OF TIME**



### IRTA Group Packaging

Camino de la Estación, s/n - 12550 Almazora (Castellón) ESPAÑA

#### Sales

ventas@irtagroup.com  
 Tel. +34 964 565 030  
 Fax +34 964 565 024  
 Móvil +34 676 547 338

#### + info

www.irtagroup.com  
<https://www.facebook.com/IRTAGROUP/>  
<https://twitter.com/irtagroup>  
<https://plus.google.com/+Irtagroup>



HIGH OUTPUT IN SMALL BAGS



MAKE 2 BAGS PER CYCLE  
MAXIMIZING PRODUCTION TIME

# HIGH PRODUCTIVITY

OPTIONS FOR  
DISCHARGING PRODUCT

**VOLUMETRIC DOSIFIER**

**MULTIHEAD WEIGHER**



## IRTA DUPLO BAGS TWO BY TWO

Its two forming tubes make two independent bags in each cycle, reducing production time by half.

MULTIFORMAT PACKAGING UNIT

# IRTA DUPLO

240 bags  
in just one minute

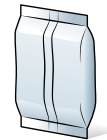

Almohadilla  
Pillow Pack

### MEASUREMENTS

Adjustable width  
50 mm - 120 mm

Adjustable length  
40 mm - 200 mm



Especially suited for packaging all kinds of small products such as sunflower seeds, fruit gums, snacks, nuts.....



SPECIALLY DESIGNED FOR



Candy



Sunflower seeds



Snacks



Nuts



Quinoa

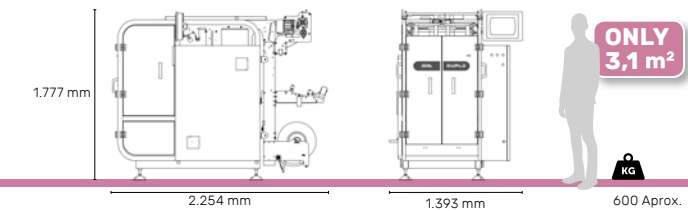

### STANDARD FEATURES

STANDARD FEATURES	IRTA DUPLO
Finish	Stainless steel
Maximum Output (240 bags/min)	120 Cycles/min.
Energy Consumption(Nominal Max Value)	5,5 KVA
Mains Voltage	230 / 400 Vca
Type of Protection	IP 35
Servomotors	Rockwell
Pneumatics	Festo
Vacuum Pump	Becker
Air Consumption	12 NI / Cycle
Movement Management & Field elements	Bus Ethernet
Control over shafts with Implemented Motion Functions	Yes
Temperature control, Welding Time & Pressure	Yes
Fast reel change with or without suction	Yes
System for centering printed film	Independent
LAN Ethernet Connection	Yes
Reel. Width / Max Diameter	550 / 400 mm
Reel Spindle	75 mm
Film pulling system	Belt drive with vacuum
End of Film Warning	Yes
Color Touch Display	10"
Interface Languages	E / EN / DE

### IRTA DUPLO



### EXPANSION KITS

- Modified atmosphere injection
- Constant heat jaws for PE film and high speeds
- Elimination of static electricity from film
- Bag vibrator
- Strings or double package
- Euro-lock / Euro-hold
- Coders, labellers...
- Product exit belts

### OPTIONS FOR DISCHARGING PRODUCT

#### VOLUMETRIC DOSIFIER



#### MULTIHEAD WEIGHER



**We manufacture to your specifications**

Contact our R+D Department and let us know your needs.