

Giró Case packer **BOX-IT**

High speed automatic case packer







*Net bag box filler system.
Up to 100 bags per minute.*



BOX-IT CASE PACKER

High performance, automatic case packer for handling net bags ranging from 500 g to 3 kg (and some specific formats up to 5 kg), designed to be set up at the end of any packing line prior to palletizing.



- 
High performance
 High output that handles up to 100 bpm
- 
Reliability and accuracy
 Optional box rejection system, equipped with a load cell which ensures that all boxes meet with the target weight parameter
- 
Labour saving
 Total automated Box Filling Process
- 
Adaptability
 Different options and solutions that adapt to all types of customers and different stages of automation

MAIN FEATURES

- High output level: up to 100 bpm
- Handles 600 x 400mm boxes or 300x400mm boxes with just an easy adjustment kit
- Suitable for carton and plastic boxes
- Connectivity to GirControl Plus for plant management and production control
- Fully enclosed to meet safety standards

2 POSSIBLE MACHINE CONFIGURATIONS

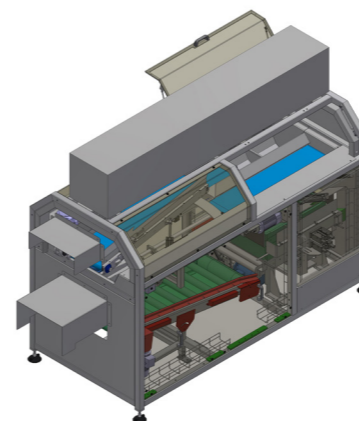

With direct conveyor

The box filled with net bags advances to the pallet directly through a conveyor.

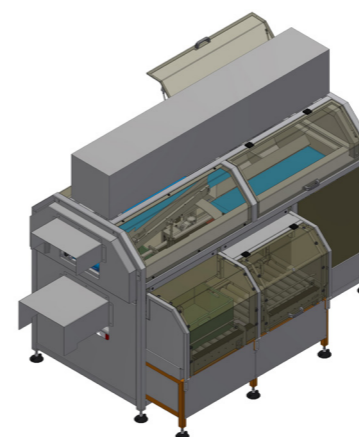

With box checkweigher

The box filled with net bags advances to a checkweigher equipped with a load cell that ensures that all packages meet the target weight parameter. Otherwise, the box is ejected to a review area on the side of the machine with a double buffer for incorrect boxes.

OTHER ACCESSORIES

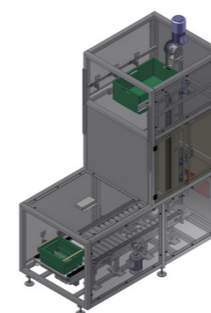

Box descender

For those facilities where the empty boxes come from an aerial conveyor and have to descend to the height of the infeed of the machine.

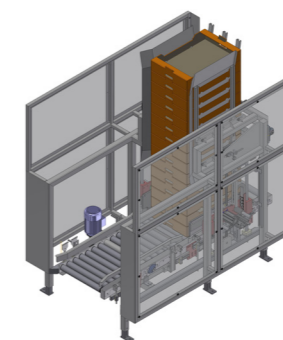

Box de-stacker

For those facilities where the empty boxes are fed stacked to give the machine more autonomy. The de-stacker singles out the boxes for filling in the machine.

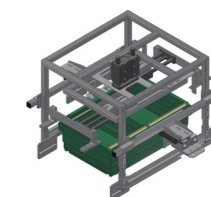

Handle checker

If working with a box with movable handles, a verifier is installed to ensure that they are always in the correct position.

TECHNICAL DATA

ELECTRICAL AND PNEUMATIC INSTALLATION BOX-IT

- Voltage: 220–380V
- Frequency: 50–60 Hz
- Power: from 3Kw to 6Kw depending on the accessories
- Minimum air pressure: 7 bars
- Average air consumption
 - Case packer: 120L/min
 - Checkweigher: 100L/min
 - Destacker: 50L/min
 - Descender: 20L/min
 - Handle checker: 50L/min

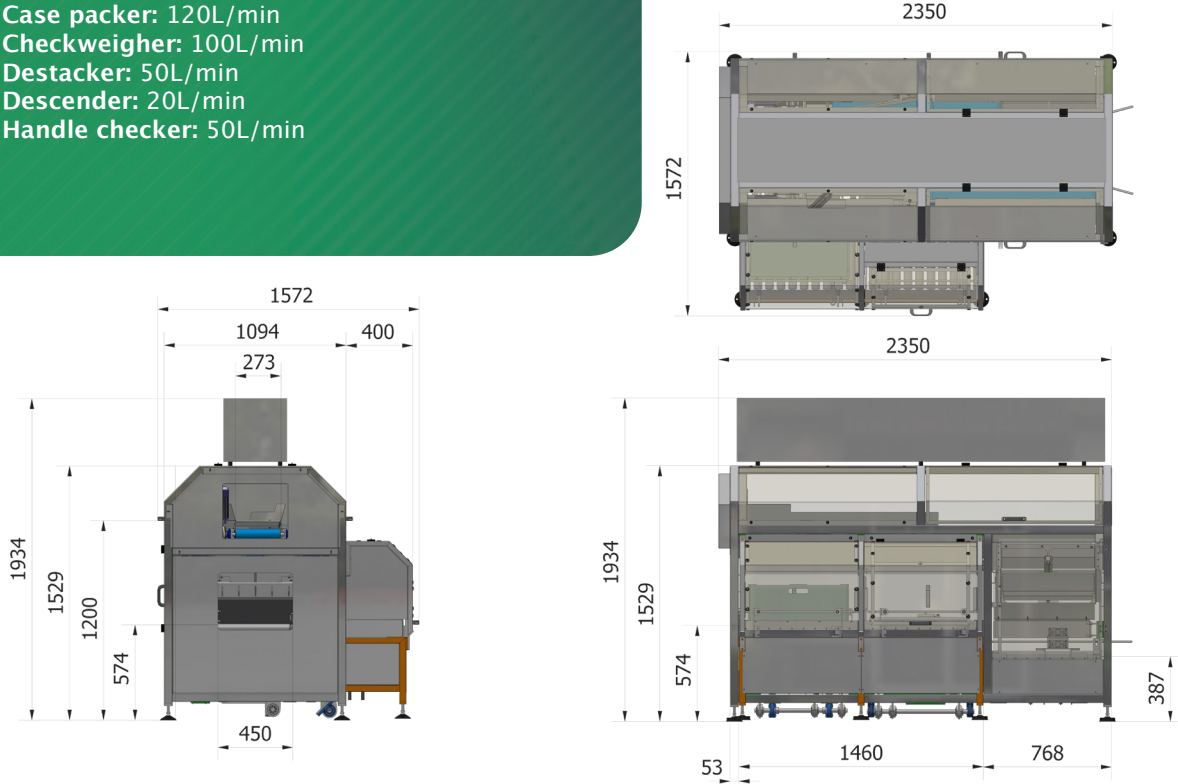

TYPICAL LAYOUT

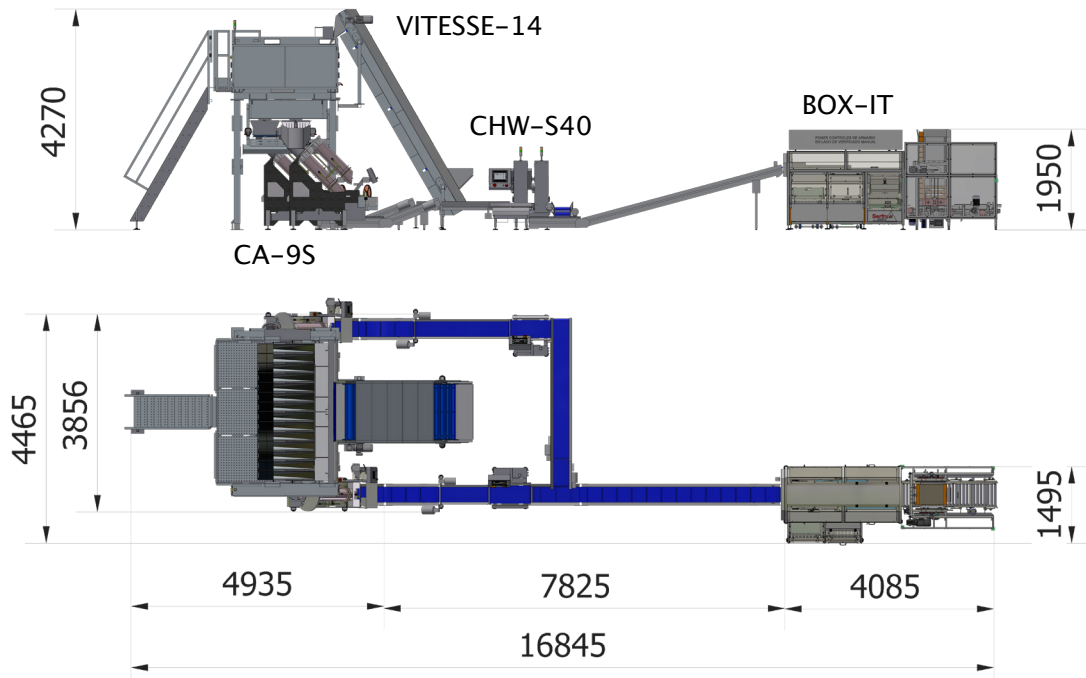

The manufacturer reserves the right to make any modification without previous notice. All the brands that appear in this catalogue belongs to Giró property.